

## Operating Instructions

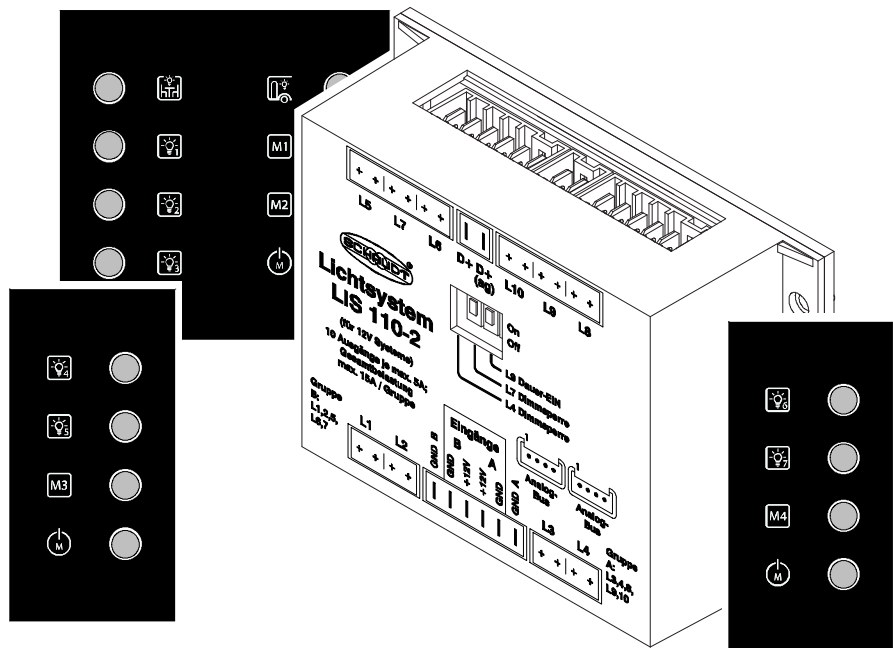

## Lighting Control System LIS 110-2 LIS 110-2 B

### Table of contents

1	Safety information .....	2
1.1	Meaning of safety symbols .....	2
1.2	General safety information .....	2
2	Introduction .....	3
3	Operation .....	3
3.1	Switching on/off and dimming the light circuits .....	4
3.2	Saving lighting scenes .....	5
3.3	Special function of light circuit 9 – always ON .....	6
3.4	Special function of light circuit 10 – awning light .....	6
3.5	Faults .....	6
4	Application and functions in detail .....	7
5	Layout .....	8
6	Maintenance .....	8
	Appendix .....	9

## 1 Safety information

### 1.1 Meaning of safety symbols



**▲ DANGER!**

Failure to comply with this sign may result in danger to life or physical condition.



**▲ WARNING!**

Failure to comply with this sign may result in injury.



**▲ ATTENTION!**

Failure to comply with the sign may result in damage to equipment or other connected loads.

### 1.2 General safety instructions

The design of the device is state-of-the-art and complies with approved safety regulations. Failure to observe the safety instructions may nonetheless lead to injury or damage to the device.

Only use the device when it is in perfect technical condition.

Any faults affecting the safety of individuals or the proper functioning of the device must be repaired immediately by specialists.



**▲ WARNING!**

Hot components

Burns:

- Only change blown fuses when the device is fully de-energised
- Blown fuses may only be replaced once the cause of the fault is known and has been rectified
- Never bypass or repair fuses
- Only use original fuses rated as specified on the device
- Device parts can become hot during operation. Do not touch them.
- Never store heat sensitive objects close to the device (e.g. temperature sensitive clothes if the device has been installed in a wardrobe)

### 2 Introduction

This instruction manual contains important information for the safe operation of equipment supplied by Schaudt. Make sure you read and follow the safety instructions provided.

The operating instructions should always be kept in the vehicle. All safety information must be passed on to other users.

**Purpose** The LIS 110-2 (B) lighting control system is a powerful system for controlling all the lighting equipment in the leisure and outer areas of a motorhome or caravan.

It provides the following functions:

- Activation and dimming of up to 10 light circuits
- Automatic switch-off of awning light after the engine is started (optional - only for motorhomes)
- Saving of up to four different lighting scenes
- Complete switch-off of all lights inside the vehicle at the press of a button. Activation of a light scene from the main light switch when the lights in the entire vehicle are switched back on.



- ▲ Versions LIS 110-2:  
Operator panels STL ...
- Versions LIS 110-2 B:  
In addition operator panels STL ... Touch (e.g. STL140)

### 3 Operation

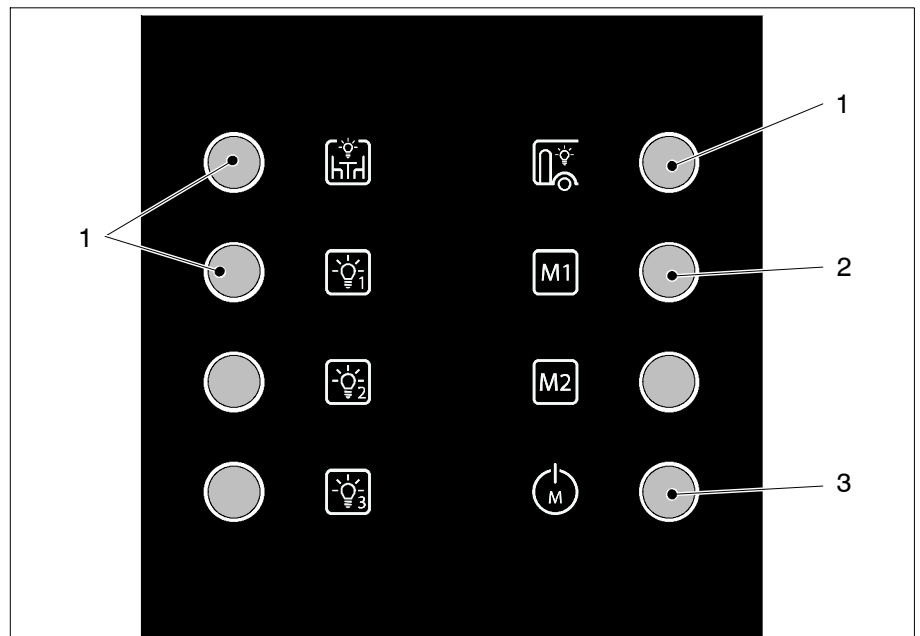
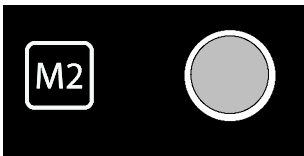

Fig. 1 Example of an operator panel layout

- 1 Up to 10 light switches
- 2 Up to 4 memory buttons
- 3 "Main light switch" button

The LIS 110-2 (B) lighting controller is controlled from one or more operator panels. Each operator panel can have a maximum of 10 light buttons, 4 memory buttons and one main light switch.

There are several different operator panels / button groups, each having different functionality. The functions are specified by different symbols next to the buttons:



- Memory button

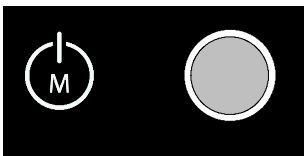

- ON/OFF symbol with an "M" for the main light switch



- Schematic furniture or vehicle parts, a bulb with digit, for the lighting circuits

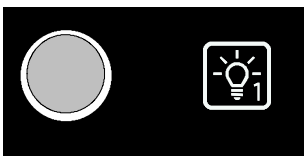

- ▲ If in doubt, please refer to the documentation provided by the vehicle manufacturer for non-ambiguous assignment of light buttons and lights.

### 3.1 Switching on/off and dimming the light circuits

The 12V supply of the vehicle must first be switched on from the operator panel of the electroblock. Initially all light circuits are switched off. Now the various light circuits can be used:

#### Switching on and off



- ▶ Briefly press the button (Fig. 1, Pos 1) for a lighting circuit
  - The lighting circuit is activated
- ▶ Briefly press again the button (Fig. 1, Pos 1) for the lighting circuit
  - The lighting circuit is deactivated

#### Dimming

The lighting circuit is initially deactivated

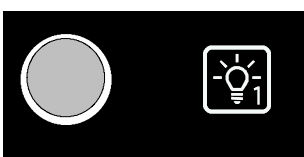

- ▶ Press the button (Fig. 1, Pos 1) of a lighting circuit and keep it pressed (longer than 1 second)
  - Dimming starts with the minimum brightness (approx. 20%)
  - The light becomes brighter slowly until the maximum brightness is reached
  - Then the light becomes darker

- ▶ Release the button (Fig. 1, Pos 1) for the lighting circuit
  - The brightness stays at the current level



- ▲ If a light switch (Fig. 1, Pos 1) is pressed and kept pressed, the dimming direction changes with every key press

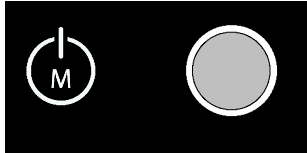

- ▶ When the "Main light switch" button (Fig. 1, Pos 3) is pressed, all lights go out simultaneously



- ▲ When leaving the vehicle, this is a simple way of ensuring that all lights are turned off and not consuming any unnecessary power during your absence.

The dimming function can be disabled for one or two lighting circuits – depending on the lighting controller settings. This means non-dimmable lights can also be connected (such as transistor lights). The lighting system is then configured accordingly during installation. As a result, the lighting circuits can only be switched on and off. Dimming with prolonged pressing of a light switch is not possible in this case. Please refer to the vehicle manufacturer's documentation for which one this is / ones these are (e.g. awning light).

### 3.2 Saving light scenes

If individual light switches are used to create a particular setting for all light circuits in the vehicle, this overall setting ("light scene") can be saved.

**Save** Proceed as follows to do this:



- ▶ Set the desired scenario using the different light switches (Fig. 1, Pos 1)
- ▶ Press a memory button (Fig. 1, Pos 2) or the "Main light switch" button (Fig. 1, Pos 3), and keep it pressed for more than 10 seconds.

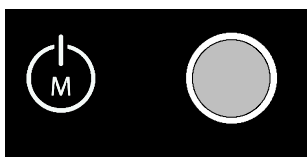

- The lighting circuits activated go out briefly, acknowledging the save process
- The light scene can now be activated from the relevant memory button

**Enabling a light scene**

- ▶ Briefly press the memory button (Fig. 1, Pos 2) – the "Main light switch" button must be pressed for longer than 0.5 seconds
  - The brightnesses for the different lighting circuits (set beforehand and stored for the appropriate M button or "Main light switch" button) adjust automatically.



- ▲ Individual lighting circuits can now be switched on and off, and dimmed, as required from the light buttons, and be switched off from the "Main light switch" button (Fig. 1, Pos 2).

### 3.3 Special function of lighting circuit 9 - always ON

Lighting circuit 9 can be configured such that it is automatically switched on when any lighting circuit is switched on (from the "Main light switch" button, a memory button or a light switch), and remains switched on until all light circuits are switched off from the "Main light switch" button.

Refer to the vehicle manufacturer's documentation for whether and which light(s)/function(s) are configured this way in the vehicle.

### 3.4 Special function for lighting circuit 10 - awning light

Lighting circuit 10 has a special function. In motorhomes, it is activated automatically when the engine is started.



▲ A prerequisite here is that the vehicle cabling is configured for it (D+ connected to LIS 110-2 (B)). Refer to the vehicle manufacturer's documentation for more information.

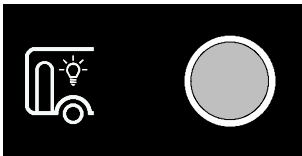

The awning light is one of the lights powered by this lighting circuit. It is therefore automatically switched off when the vehicle is moving.

### 3.5 Faults

A blown fuse or flat battery is usually the cause of a fault.

#### Start the engine

If the battery is discharged, the 12V supply can be reestablished by starting the engine.

#### Flat vehicle fuses

If fuses are blown: Refer to the instruction manual for the vehicle for information on voltage distribution and fusing.

Please contact our customer service address if you cannot rectify the fault using the following table. If this is not possible, such as when you are abroad, a specialist workshop will be able to repair the device. In this case, you must ensure that the warranty is not invalidated by incorrect repairs being carried out. Schaudt GmbH will not accept any liability for damage resulting from such repairs.

Fault	Possible cause	Remedy
One or more lighting circuits cannot be switched on.	No power to one of the voltage inputs.	Check supply from electro-block / 12V supply: - Fuse blown: replace if necessary - Supply unit off: Switch on unit - Supply unit defective: Contact customer service
	Defective wiring	Check/replace connector cables and connectors
	LIS 110-2 (B) defective	Contact customer service

Fault	Possible cause	Remedy
No lighting circuit can be switched on.	Flat battery	Charge the battery
	LIS 110-2 (B) defective	Contact customer service
Light scenes cannot be saved	LIS 110-2 (B) defective	Contact customer service
A lighting circuit can not be dimmed	This is a non-dimmable light, e.g. a transistor light in the kitchen area.	-
	Incorrect LIS 110-2 (B) setting	Contact customer service

### 4 Application and functions in detail

The LIS 110-2 (B) light controller is the central controller for leisure lights in the vehicle.

Operator panels for the LIS 10-2 light control system are positioned at appropriate places within the vehicle.

In the simplest case, an operator panel only has 3 button functions. An operator panel has a maximum of 8 buttons for the lighting circuits, 4 memory buttons and an "Everything OFF" button (refer also to Section 3).

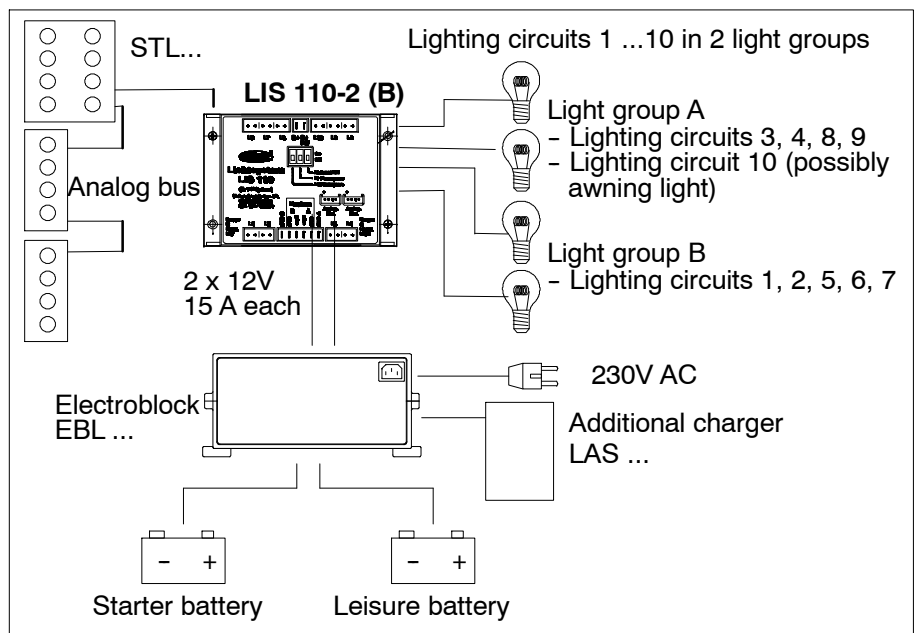

Fig. 2 Main layout of the LIS 110-2 (B) light control system

**System devices** An EBL ... electroblock or comparable 12V supply must be connected for operation. This provides a 2 x 12V supply for the LIS 110-2 (B) light controller.

These two supply voltages are galvanically isolated from each other. This way the other lighting circuits can continue to be used when one of the 12V supplies fails.

## **5 Layout**

The LIS 110-2 (B) light controller is a built-in unit and can be housed anywhere in the vehicle.

## **6 Maintenance**

The LIS 110-2 (B) light control system requires no maintenance.

**Cleaning** Clean the devices with a soft, slightly damp cloth and a mild detergent. Never use spirit, thinners or similar substances. Do not allow fluid to penetrate the inside of the devices.

© No part of this manual may be reproduced, translated or copied without express written permission.



## **Appendix**

### **A EC Declaration of Conformity**

Schaudt GmbH hereby confirms that the design of the LIS 110-2 (B) light control system complies with the following relevant regulations:

The original EC declaration of conformity is available for reference at any time.

**Manufacturer** Schaudt GmbH, Elektrotechnik & Apparatebau

**Address** Planckstraße 8  
88677 Markdorf  
Germany

### **B Customer service**

**Customer service** Schaudt GmbH, Elektrotechnik & Apparatebau  
Planckstraße 8  
88677 Markdorf, Germany

Phone: +49 7544 9577-16

Email: [kundendienst@schaudt-gmbh.de](mailto:kundendienst@schaudt-gmbh.de)

Web: [www.schaudt-gmbh.de](http://www.schaudt-gmbh.de)

**Send in device** Returning a faulty device:

- ▶ Complete and enclose the fault report, see Appendix D.
- ▶ Send it to the addressee (free delivery).

### **C Accessories**

**Operator panels** Any number of operator panels, configuration can be changed as option

### **D Fault report**

In the event of damage, please fill in the fault report and send it with the faulty device to the manufacturer.

Device type: \_\_\_\_\_  
Item no.: \_\_\_\_\_  
Vehicle:           Manufacturer: \_\_\_\_\_  
                          Model: \_\_\_\_\_  
                          Own installation?           Yes  No   
                          Upgrade?                     Yes  No   
Upstream overvoltage protection?           Yes  No

Following fault has occurred (please tick):

- Electrical consumers do not work – which?  
  (please specify below)
- Switching on and off not possible
- Persistent fault
- Intermittent fault/loose contact

Other comments:

---

---

---

---

---

---

---

---

---

---

---

### E Block diagram/wiring diagram

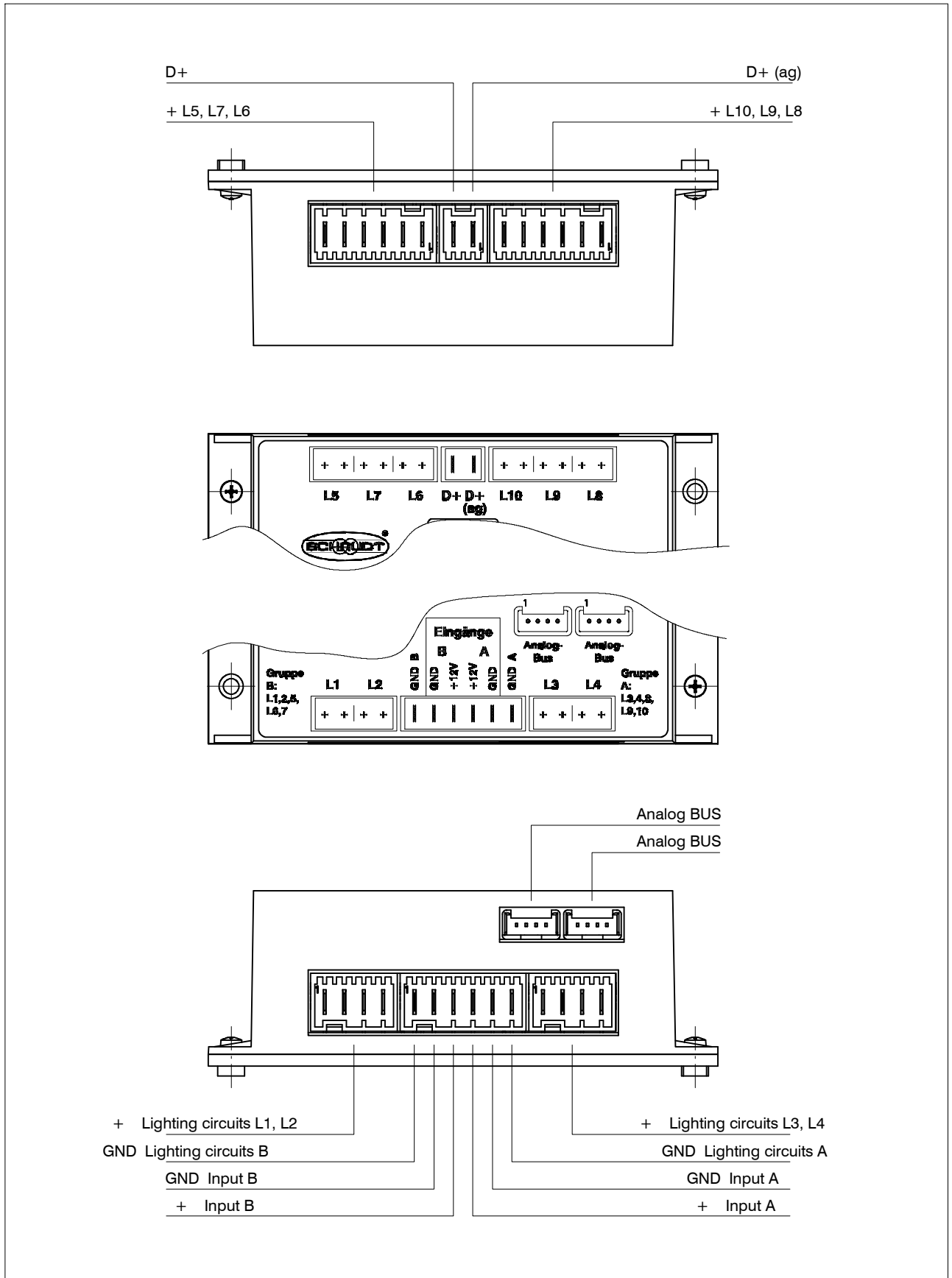

(blank page)